



Spectrum Management and Telecommunications

Compliance Specification for Terminal Equipment, Terminal Systems,
Network Protection Devices, Connection Arrangements and Hearing Aids Compatibility

Part V: Requirements and Test Methods for Magnetic Output from Handset Telephones for Hearing Aid Coupling and for Receive Volume Control

Preface

Compliance Specification CS-03, Part V, issue 9, amendment 3, *Requirements and Test Methods for Magnetic Output from Handset Telephones for Hearing Aid Coupling and for Receive Volume Control*, replaces CS-03, Part V, issue 9, amendment 2, dated January 2017.

The following are the main changes:

1. removed Receiver Objective Loudness Rating (ROLR) requirements
2. updated receive volume control requirements to reference only ANSI/TIA-4965 (section 9)
3. added additional test report requirements (section 10)
4. made editorial changes and clarifications, as appropriate

Issued under the authority
of the Minister of Innovation, Science and Industry

Martin Proulx
Director General
Engineering, Planning and Standards Branch

Contents

1.	Scope	1
2.	Coming into force.....	1
3.	Purpose and application.....	1
4.	Exemptions.....	1
5.	Definitions	1
6.	Normative references	2
7.	General requirements.....	3
8.	Magnetic output	3
	8.1 Requirements.....	3
	8.2 Method of measurement.....	6
9.	Telephone receive volume control.....	9
	9.1 Requirements.....	9
	9.2 Method of measurement.....	10
10.	Test report requirements	10

1. Scope

Compliance Specification CS-03, Part V, *Requirements and Test Methods for Magnetic Output from Handset Telephones for Hearing Aid Coupling and for Receive Volume Control*, sets out the compliance requirements for hearing aid compatibility and volume control features for handset telephones.

2. Coming into force

This document will be in force upon publication on Innovation, Science and Economic Development Canada's (ISED) website.

3. Purpose and application

The volume control gain feature gives individuals with a hearing impairment the ability to increase the volume of a device. Hearing aid compatibility features will accommodate individuals with hearing aids and cochlear implants. These features minimize potential issues generated by the use of these hearing aids and enhance the hearing experience of users using handset telephones.

4. Exemptions

Cellular telephones and secure telephone units are exempt from the requirements of this Part.

5. Definitions

Artificial ear: A device for calibrating earphones that incorporate an acoustic coupler and a calibration microphone for measuring sound pressure. These devices have an overall acoustic impedance similar to that of the average human ear over a given frequency band.

Conversational gain: The level of an acoustic output from a telephone relative to the acoustic level that would be present in a face-to-face conversation at a distance of 1 metre. This reference acoustic level for a face-to-face conversation is 64 dBSPL for binaural listening. However, for monaural listening (such as when using a handset), the reference acoustic level is 70 dBSPL.

Note: When only one ear is used for listening, a talker is perceived to be about 6 dB quieter than when both ears are used. Therefore, to be perceived at an equivalent loudness, the level at a single ear should be about 6 dB louder.

Conversational gain = (measured dBSPL level – 70 dBSPL) dB

Ear Cap Reference Point (ECRP): The intersection of the external ear-cap reference plane with a normal axis through the effective acoustic centre of the sound outlet ports. Generally, the acoustic centre of the sound outlet ports is at the centre of their distribution.

Handset: The part of a telephone set that is held to the ear and mouth. It contains the speaker (receiver) and the microphone (transmitter).

Measurement axis: The axis parallel to the reference axis which may be displaced from the axis by a maximum of 16 mm. Within this constraint, the measurement axis may be located where the radial and axial field intensity measurements are optimum with regard to the requirements. For a handset with a centred receiver and a circular symmetric magnetic field, the reference axis and the measurement axis coincide.

Measurement plane: The planar area parallel to, and 10 mm in front of, the reference plane.

Recommended Test Position (RTP): A manufacturer may specify a recommended test position (RTP). This can be described as a translation, followed by a rotation, followed by an application of force. The force applied shall be 10 Newton (N).

Reference axis: The axis which is normal to the reference plane and which passes through the centre of the receiver cap (or the centre of the hole array for handset types that do not have receiver caps).

Reference plane: The planar area containing points of the receiver-end of the handset that, in normal handset use, rests against the ear.

Standard Test Position (STP): The high leak standard test position as specified in IEEE Std 269 with an applied force of 10 N.

6. Normative references

This regulatory standard refers to the following publications, and where such reference is made, it shall be to the edition listed below. Should there be discrepancies between the requirements stated in CS-03, Part V, and the relevant text of the publications referenced in this section, CS-03, Part V, shall take precedence.

- ANSI/TIA-4965, *Telecommunications Telephone Terminal Equipment Receive Volume Control Requirements for Digital and Analog Wireline Handset Terminals* (latest published edition)
- TIA TSB-31-D, *Telecommunications Telephone Terminal Equipment Rationale and Measurement Guidelines for U.S. Network Protection*
- ANSI/TIA-920.110-B, *Telecommunications - Communications Products - Transmission Requirements for Digital Interface Communications Devices with Handsets*
- IEEE Std 269, *IEEE Standard Methods for Measuring Transmission Performance of Analog and Digital Telephone Sets, Handsets, and Headsets*
- IEEE Std 1027-1996, *IEEE Standard Method for Measurement of the Magnetic Field in the Vicinity of a Telephone Receiver*

Acronyms

ANSI – American National Standards Institute
IEEE – Institute of Electrical and Electronics Engineers
TIA – Telecommunications Industry Association
TSB – Telecommunications Systems Bulletin

7. General requirements

Handset telephones must meet all applicable technical requirements of CS-03, [*Compliance Specification for Terminal Equipment, Terminal Systems, Network Protection Devices, Connection Arrangements and Hearing Aids Compatibility*](#), including the technical requirements of this Part. These requirements apply to all analog and digital handset telephones.

8. Magnetic output

This section provides the requirements and the measurement methods for magnetic output specifications.

8.1 Requirements

The parameters below, which describe the magnetic field at points in the measurement plane, shall be used to ascertain adequacy for magnetic coupling:

- axial field intensity
- radial field intensity
- magnetic field intensity frequency response

8.1.1 Axial field intensity

When measured in accordance with the requirements specified in section 8.2 of this Part, the axial component of the magnetic field directed along the measurement axis and located at the measurement plane shall be greater than -22 dB relative to 1 ampere per metre (A/m), for an input of -10 dBV at 1000 Hz (see figure 1 and figure 2, below).

If the magnitude of the axial component exceeds -19 dB relative to 1 A/m, relaxation in the frequency response is permitted (see figure 3 below).

8.1.2 Radial field intensity

When measured in accordance with the requirements specified in section 8.2, radial components of the magnetic field shall be greater than -27 dB relative to 1 A/m, for an input of -10 dBV at 1000 Hz (see figure 1 and figure 2, below) when measured at four points (90 degrees apart) and at a distance greater than or equal to 16 mm from the measurement axis (as selected in the axial field intensity measurement).

8.1.3 Magnetic field intensity frequency response

The frequency response of the magnetic field intensity as measured in section 8.2 shall fall within the acceptable region of figure 3 and figure 4 below, over a frequency range of 300 Hz to 3300 Hz.

- (a) For receivers with an axial field intensity that is greater than -19 dB relative to 1 A/m, when measured in accordance with the requirements specified in section 8.2, the frequency response shall fall within the acceptable region specified in figure 3.
- (b) For receivers with an axial field intensity that is less than -19 dB but greater than -22 dB relative to 1 A/m, when measured as specified in section 8.2, the frequency response shall fall within the acceptable region specified in figure 4.

The coil will need to be recalibrated in order to establish absolute field intensity at 1 kHz and relative response across the frequency band of interest. The procedures for calibrating the probe coil are provided in IEEE Std 1027-1996, [*IEEE Standard Method for Measurement of the Magnetic Field in the Vicinity of a Telephone Receiver*](#).

Figure 1: Reference and measurement planes and axis

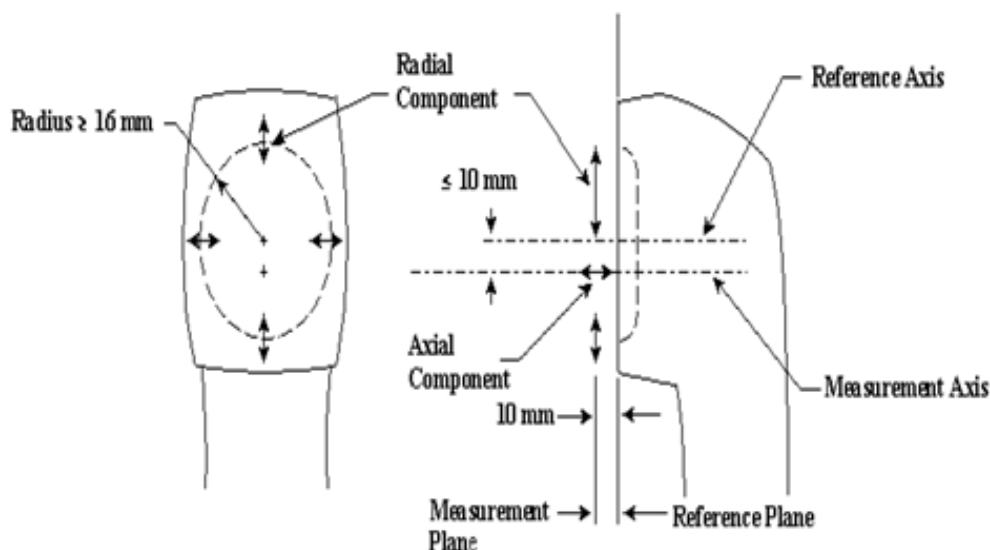
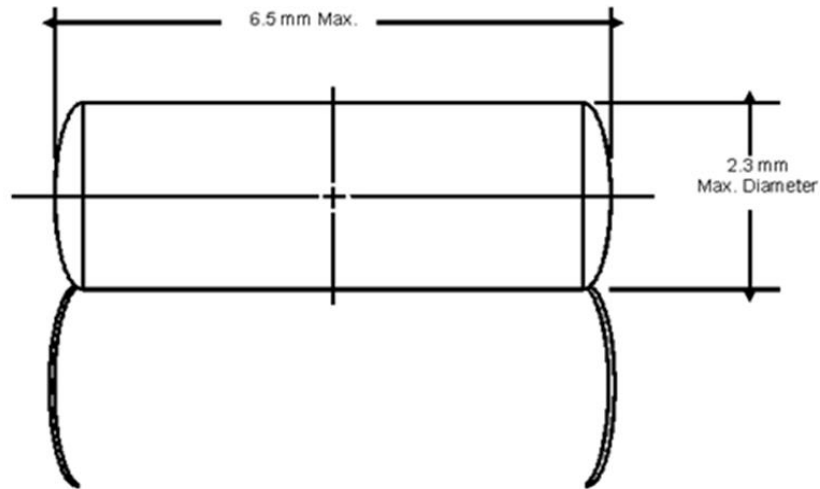

Figure 2: Typical probe coil (magnetic material core) parameters



Typical Parameters of Probe Coil

DC resistance: 900 Ohm
 Inductance: 150 mH
 Sensitivity: -60 dBV/(A/m)
 For calibration see IEEE Standard 1027, Section 5.0.

Figure 3: Magnetic field intensity frequency response for receivers with an axial field that exceeds -19 dB relative to 1 A/m

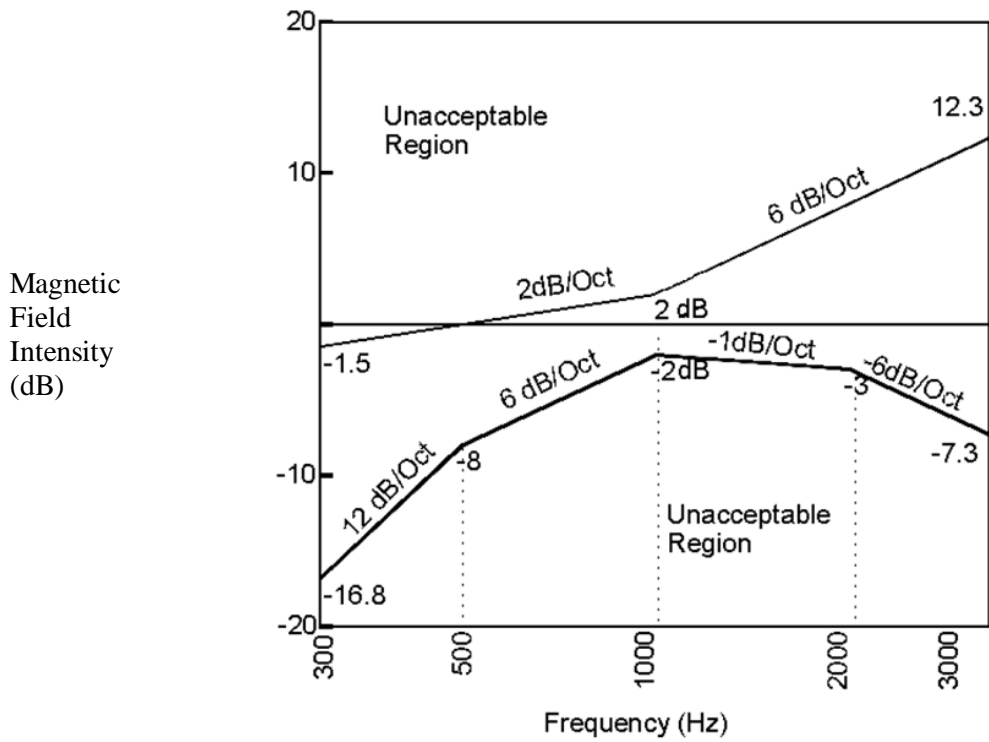
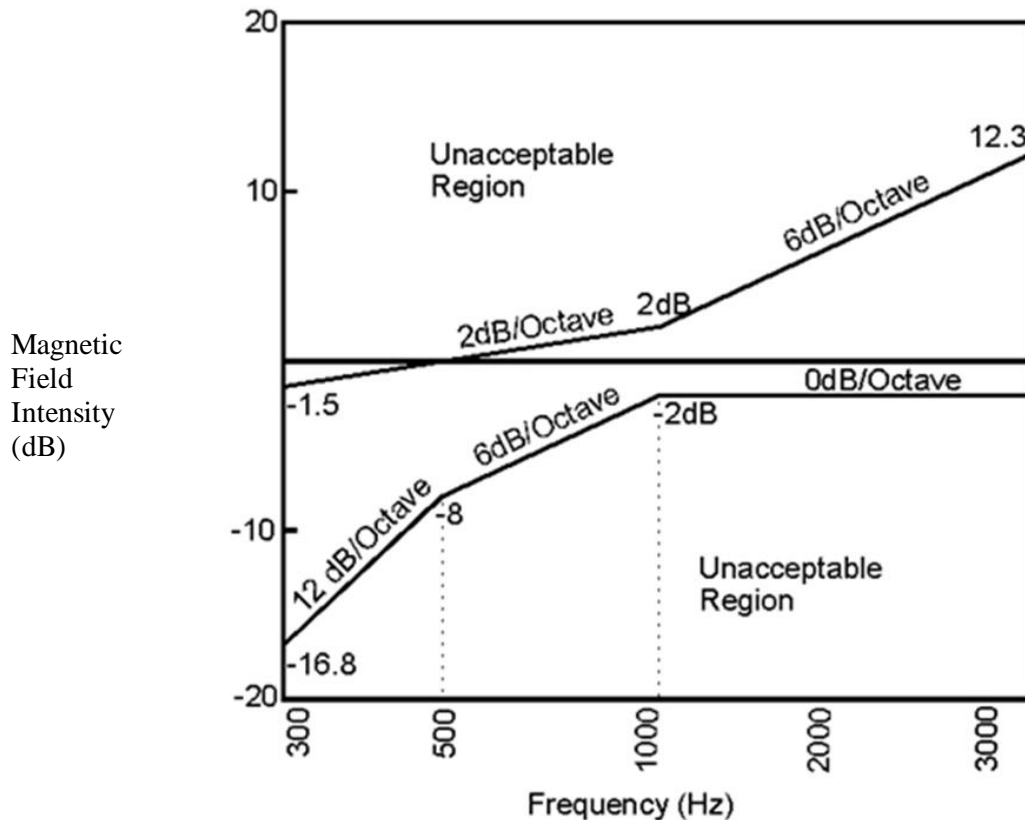

Figure 4: Magnetic field intensity frequency response for receivers with an axial field that is less than -19 dB but greater than -22 dB relative to 1 A/m



8.2 Method of measurement

The methods of measurement for analog and digital telephones are described below.

8.2.1 Analog telephones

The following methods of measurement are applicable to analog telephones:

- (a) Arrange the DC feed circuit so that the total resistance between its tip and ring terminals is 1650 ohms (Ω) and the battery voltage is 48 volts DC.
- (b) Connect the terminal equipment to the test circuit as shown in figure 5, below.
- (c) With the terminal equipment off-hook, set the signal source frequency to 1 kHz and adjust its level to -10 dBV. Average the selective level meter to pass 1 kHz.
- (d) With reference to the definitions contained in section 5 of this Part, locate the reference axis, position the probe in an axial orientation on the receiver of the handset and move the probe across the surface of the receiver to find the measurement axis. Record the voltage measured.

Notes:

- The measured voltage must be converted into magnetic field strength. This conversion requires knowledge of the probe's sensitivity as established through calibration.
 - For the purpose of repeating these measurements, it is useful to note the measurement axis location. The measurement axis is normally considered as that location within the prescribed distance from the reference axis where the maximum field intensity is observed. However, the measurement axis may be selected as a location within the prescribed distance from the reference axis that is to the optimum advantage to satisfy the axial and radial requirements. Once a measurement axis is established, it is used as a basis for all measurements.
- (e) With the probe in an axial orientation and located at the measurement axis, set the signal source to sweep the band of frequencies from 300 Hz to 3300 Hz. Arrange the selective voltmeter to track the signal source frequency. Record the measurement results, taking into account the variation in sensitivity that occurs with changing frequency. Plot the frequency response relative to 1 kHz.
- (f) Set the signal source as in step (c). Position the probe in a radial orientation at 16 mm from the measurement axis. Move the probe in a radial direction, away from measurement axis. Record the maximum voltage observed.
- (g) Repeat step (f) to obtain a total of four measurements, each separated by 90 degrees around the circumference of the receiver.

Figure 5: Measurement block diagram

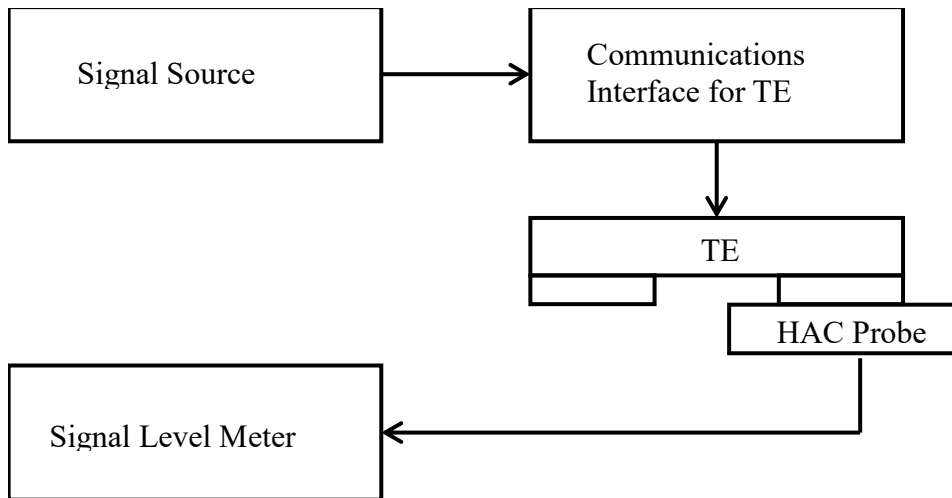

8.2.2 Digital telephones

The following methods of measurement are applicable to digital telephones:

- (a) For digital telephones, an appropriate input test level that produces an equivalent acoustic level to analog sets (nominal +0 dBPa) must first be determined, with the receive volume control set to its nominal gain level. The acoustic output of the handset is measured instead of the magnetic output to determine the input test level.
- (b) Place the telephone receiver in the Type 3.3 artificial ear, using the high leak condition specified in ANSI/TIA-920.110-B, and connect the telephone set to the circuit interface. Alternatively, the Type 1 artificial ear may be used if a seal can be achieved between the handset and the artificial ear without the use of sealing putty or similar materials.
- (c) Apply a 1000 Hz input signal from a sinewave generator and measure the microphone output signal using an AC voltmeter. Determine the sound pressure produced in the artificial ear, taking into account the microphone sensitivity (in dBV/Pa), the gain (if any) of the microphone amplifier, the gain or loss of the bandpass filter, and the reading of the AC voltmeter (in dBV). Adjust the input level to produce +0 dBPa at 1000 Hz. Record the input level required to produce +0 dBPa at 1000 Hz, as this is the input level determined for the magnetic field measurement.
- (d) Connect the terminal equipment to the test circuit.
- (e) With the terminal equipment off-hook, set the signal source frequency to 1 kHz and adjust its level to the input level determined in step (c). Average the selective level meter to pass 1 kHz.
- (f) With reference to the definitions contained in section 5 of this Part, locate the reference axis, position the probe in an axial orientation on the receiver of the handset and move the probe across the surface of the receiver to find the measurement axis. Record the voltage measured.

Notes:

- The measured voltage must be converted into magnetic field strength. This conversion requires knowledge of the probe's sensitivity as established through calibration.
 - For the purpose of repeating these measurements, it is useful to note the measurement axis location. The measurement axis is normally considered as that location within the prescribed distance from the reference axis where the maximum field intensity is observed. However, the measurement axis may be selected as a location within the prescribed distance from the reference axis that is to the optimum advantage to satisfy the axial and radial requirements. Once a measurement axis is established, it is used as a basis for all measurements.
- (g) With the probe in an axial orientation and located at the measurement axis, set the signal source to sweep the band of frequencies from 300 Hz to 3300 Hz. Arrange the selective voltmeter to track the signal source frequency. Record the measurement results, taking into account the variation in sensitivity that occurs with changing frequency. Plot the frequency response relative to 1 kHz.
- (h) Set the signal source as in step (e). Position the probe in a radial orientation at 16 mm from the measurement axis. Move the probe in a radial direction away from measurement axis. Record the maximum voltage observed.
- (i) Repeat step (h) to obtain a total of four measurements, each separated by 90 degrees around the circumference of the receiver.

9. Telephone receive volume control

This section provides the requirements and the measurement methods for volume control specifications.

9.1 Requirements

An analog, digital or IP-based telephone set shall be equipped with a receive volume control that provides 18 dB of conversational gain (minimum) and up to 24 dB of conversational gain (maximum) through the receiver in the handset of the telephone. The maximum conversational gain of 24 dB in the handset of the telephone may be exceeded provided that one of the following precautions is taken to minimize the likelihood of damage to individuals with normal hearing:

- (a) the amplified receive capacity automatically resets to a conversational gain level of less than 24 dB when the telephone is caused to pass through a proper on-hook transition;

or, without automatic volume reset,

- (b) an override switch located on the equipment is used, such that it will not be susceptible to accidental engagement. Clear labelling near the override switch and a caution note printed in the user manual shall be required to observe safe operating practices. This switch shall also enable a bright indicator light, prominently displayed on the front of the telephone, with an accompanied printed notification of high amplification present at the handset receiver. A printed warning

message in braille shall be supplied for visually impaired persons. The message shall be capable of securely attaching to the back of the handset to indicate that a high-volume setting may be engaged.

9.2 Method of measurement

Compliance with receive volume control requirements for digital and analog wireline handset terminals is demonstrated by employing the conversational gain method of measurement as specified in the latest issue of ANSI/TIA-4965.

10. Test report requirements

In addition to the reporting requirements set forth in annex D of Terminal Attachment Program Procedure DC-01, [Procedure for Declaration of Conformity and Registration of Terminal Equipment](#), the test report shall include:

- a) The handset position used during the testing (i.e. Standard Test Position (STP) or Recommended Test Position (RPT)). When the RPT is used, then the test report shall include:

MECRP (Manufacturer-defined Ear Cap Reference Point) (Delta from actual ECRP)

Axis	Delta (mm)
y	
z	

Angle settings

Angle	Delta from standard angle (°)
A	
B	
C	

Application force (N)	
-----------------------	--

- b) For digital and IP phones, the narrowband and wideband codec used during testing must be reported.